

INSTALLATION INSTRUCTIONS

MOBILE WALL END CARRIAGE

UPRITE/BASE BRACKET LIMITATIONS

<u>MOBILE GONDOLA UPRITE LIMITATIONS</u>	
BASE BRACKET SIZE COMBINATION	MAXIMUM UPRITE HEIGHT
13/13	NOT ALLOWED
13/16	78
13/19	90
13/22	102
13/25	114
16/16	90
16/19	102
16/22	114
16/25	120
19/19	114
19/22	120
19/25	120
22/22	120
22/25	120
25/25	120

- For use with Low Base NOM 13-25 base brackets only.
- To use the Wall End Positioner Top Cap, the uprite height used on the Mobile Wall End Display must be the same height or shorter than the Mobile Gondola System uprite height.

IMPORTANT LOADING INFORMATION

- The maximum rated load for the Mobile Wall End Display is 500 lbs evenly distributed
- The Mobile Wall Display must always be bolted to a Mobile Gondola.
- To prevent tipping, do not move a loaded Mobile Gondola.

NOTE: Always use more than one person to assemble this system.



INSTALLATION INSTRUCTIONS

MOBILE WALL END CARRIAGE

NOTE: Mobile Wall End Display is NOT to be used as a separate unit! It MUST be bolted to a Mobile Gondola!

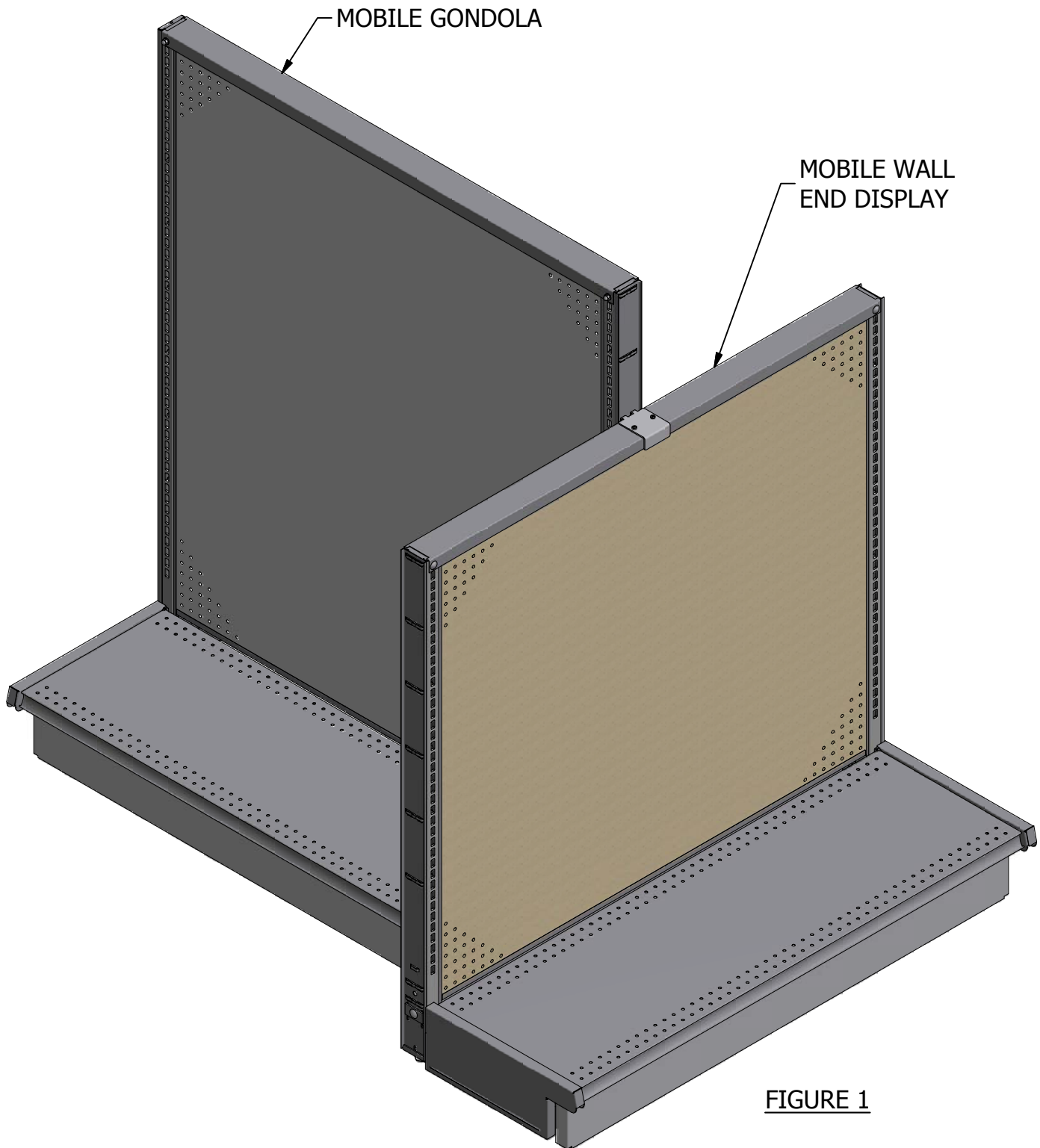

FIGURE 1

INSTALLATION INSTRUCTIONS

MOBILE WALL END CARRIAGE

STEP 1: Assemble Uprites and Base Brackets according to standard shelving instructions 01-13.

STEP 2: Attach Casters to Mobile Wall End Carriage Assembly - two per Carriage Assembly. Insert threaded stems of Casters through large holes in Carriage Assembly and secure with 1/2" Lock Washers and 1/2"-13 Hex Nuts provided. (3/4" wrench required.)

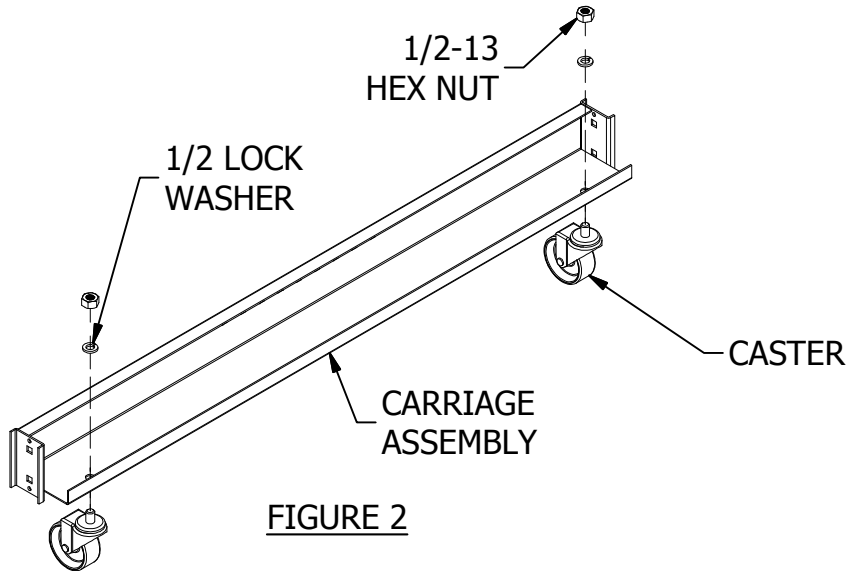

STEP 3: Place Load Spreader over lower, round hole on outside of Uprite and insert a Carriage Bolt thru Load Spreader & Uprite.

STEP 4: Align upper, square hole in end of Carriage Assembly with Carriage Bolt and slide Assembly onto bolt. Secure with Lock Washer & Hex Nut. Tighten FINGER TIGHT ONLY. (See Figure 3).

STEP 5: Repeat Steps 3 and 4 for second Uprite.

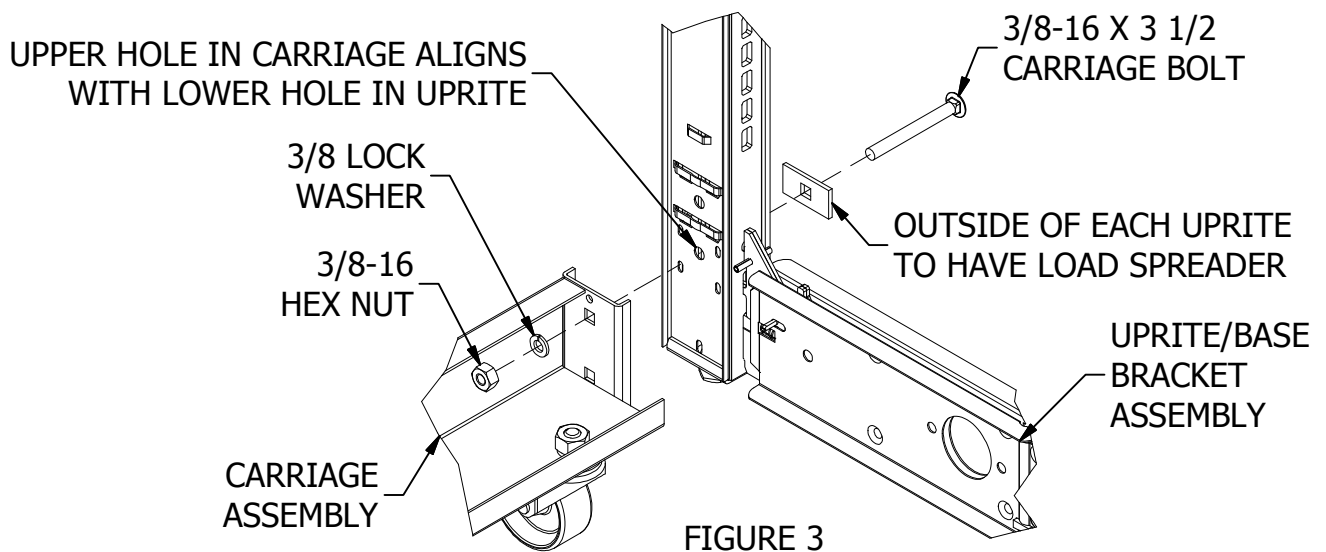

INSTALLATION INSTRUCTIONS

MOBILE WALL END CARRIAGE

STEP 6: Attach Casters to Mobile Gondola Carriage - two per Carriage. Insert threaded stems of Casters through large holes in Carriage and secure with 1/2" Lock Washers and 1/2"-13 Hex Nuts provided. (3/4" wrench required.)

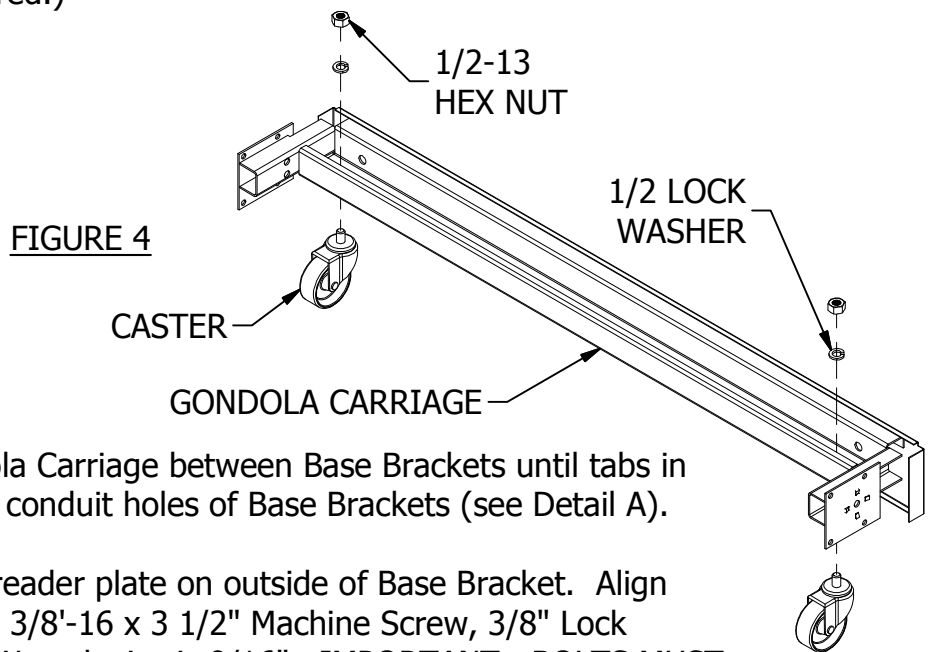

STEP 7: Slide assembled Mobile Gondola Carriage between Base Brackets until tabs in end plates fit into 2" diameter conduit holes of Base Brackets (see Detail A).

STEP 8: At each Upright, place Load Spreader plate on outside of Base Bracket. Align holes and secure in place with 3/8"-16 x 3 1/2" Machine Screw, 3/8" Lock Washer, & 3/8"-16 Hex Nut. Wrench size is 9/16". **IMPORTANT: BOLTS MUST BE FIRMLY TIGHTENED DOWN. TIGHTEN 2 FULL TURNS AFTER LOCK WASHER IS FULLY COMPRESSED AND NUT IS SNUG.**

STEP 9: Tighten hardware on Mobile Wall End Carriage Assembly at this time.

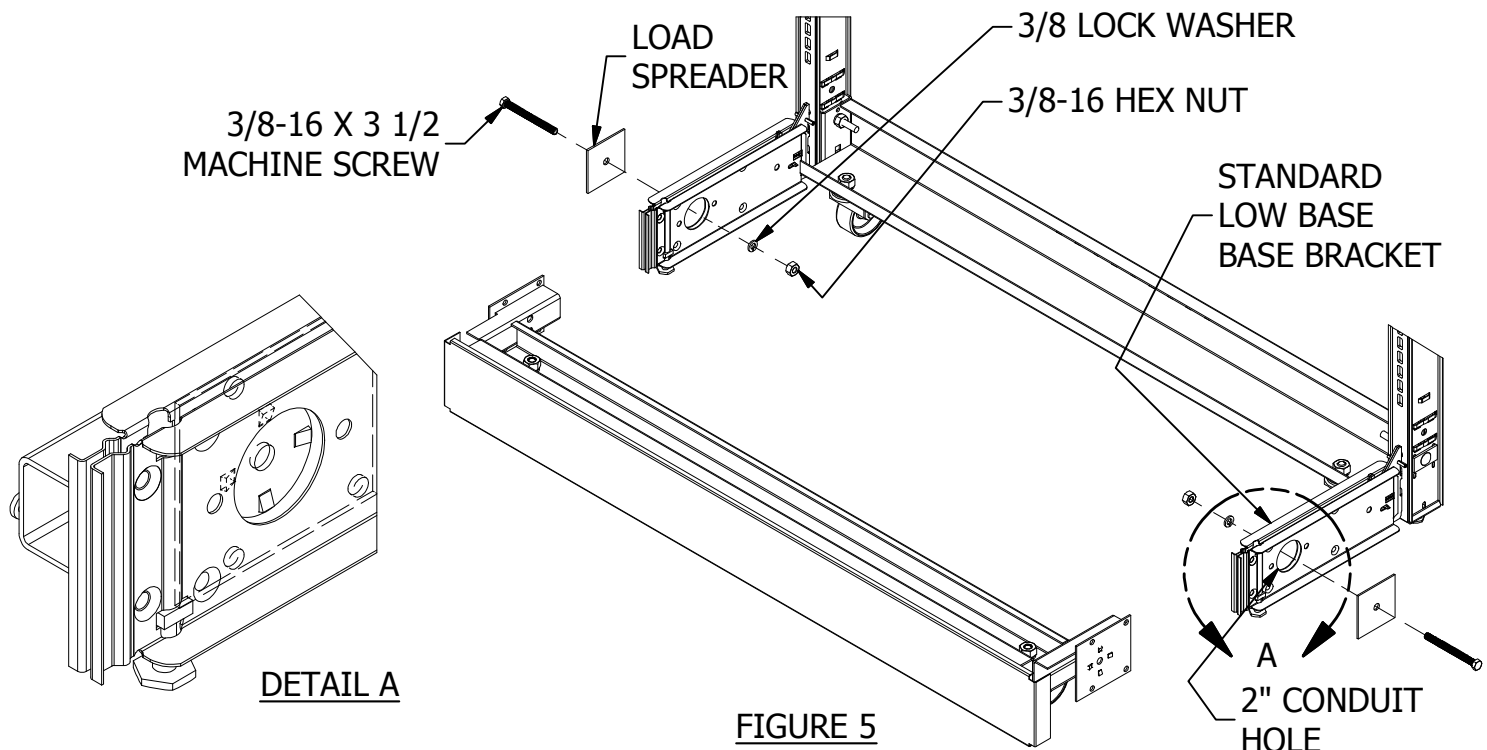

INSTALLATION INSTRUCTIONS

MOBILE WALL END CARRIAGE

STEP 10: Center Mobile Wall End up against end of Mobile Gondola. Align appropriate hole in Mobile Wall End Carriage with the hole in the end gondola upright. Attach units together with 3/8"-16 x 3 1/2" Carriage Bolt, Lock Washer, Nut, and Load Spreader as shown.

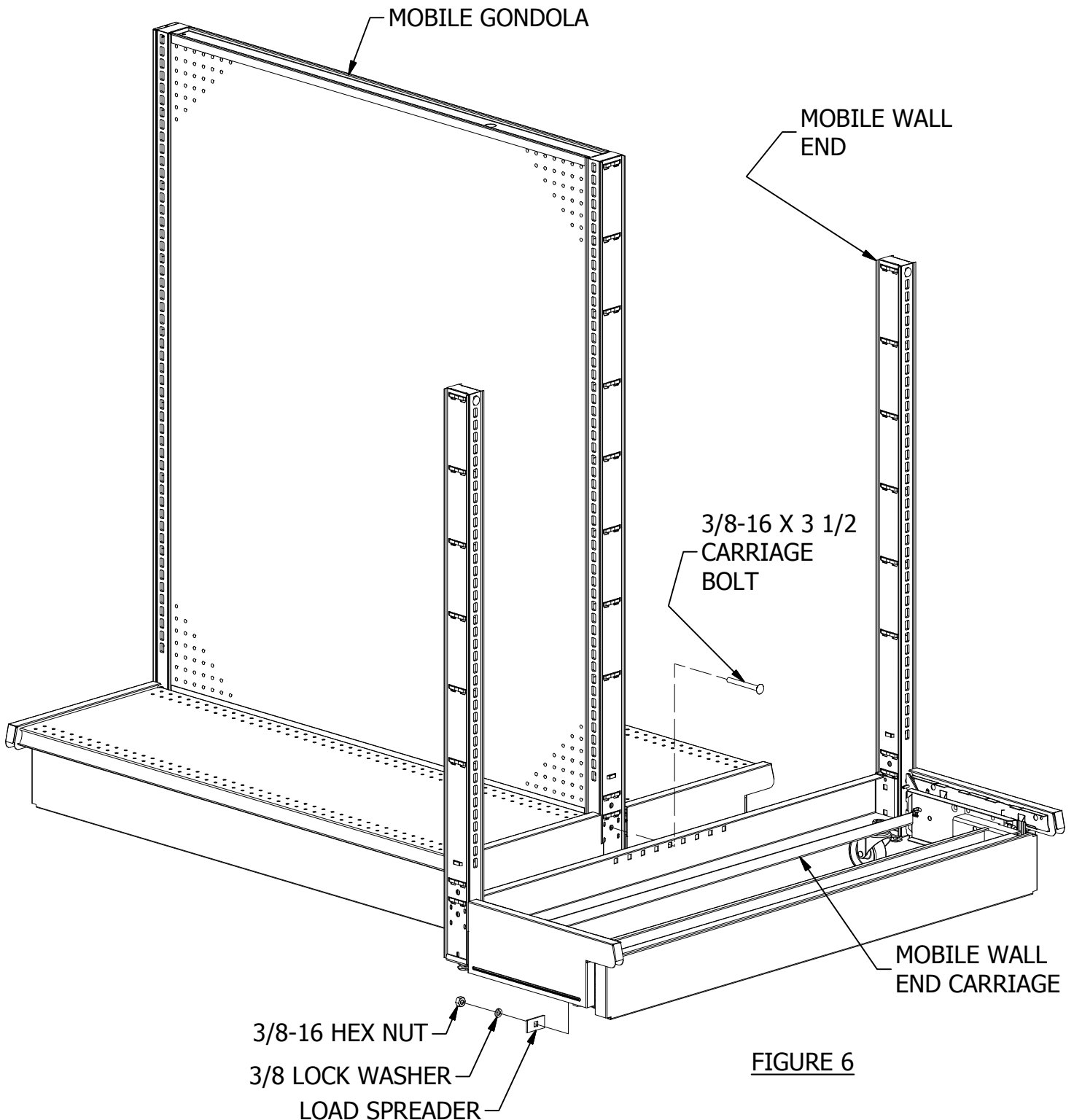

FIGURE 6

INSTALLATION INSTRUCTIONS

MOBILE WALL END CARRIAGE

STEP 11: Install Bottom Rail, Center Rail (if required), Top Rail, and Backs.

STEP 12: Install Upright End Trims.

STEP 13: Place Rail Hold Down on top of Mobile Wall End. Align holes with top slots in Uprights.

STEP 14: Secure Rail Hold Down with 5/16" Carriage Bolt, 5/16" Lock Washer, and 5/16" Acorn Nut. Tighten Acorn Nut until Lock Washer is compressed.

STEP 15: Install Wall End Positioner Top Cap.

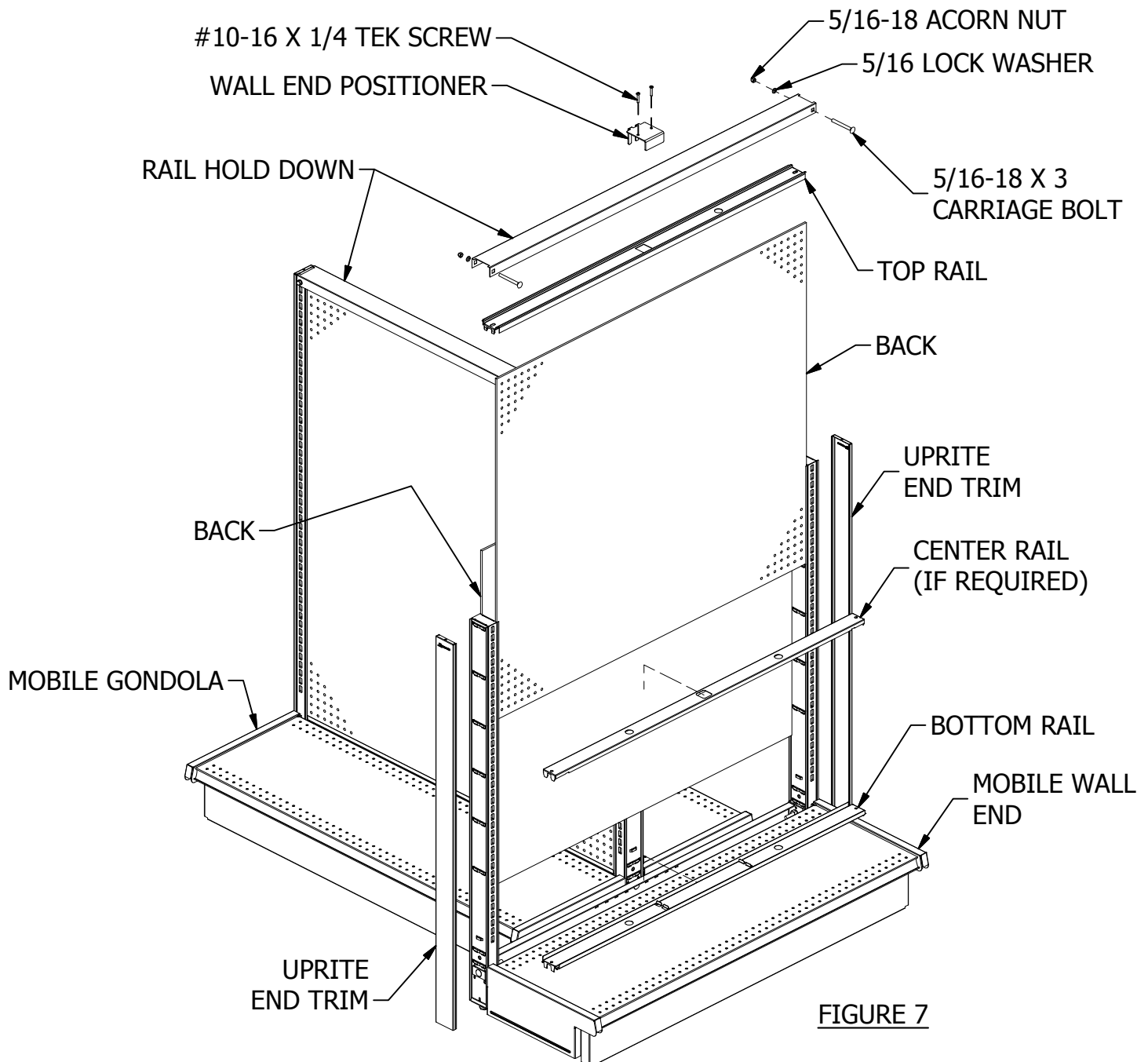

FIGURE 7